

AMANO

COMPUTERIZED TIME RECORDER

MJR-8500 SERIES

PROGRAM/USER'S MANUAL



TABLE OF CONTENTS

1. GENERAL	1
Specifications	1
Hardware Diagram	2
2. INSTALLATION	3
Wall Mounting	3
3. GETTING STARTED	4
Keypad	4
Function Guide	5
Sample Cards:	6
a) Employee Time Card	6
b) Authorization Cards	7
c) Report Card	8
d) Program Check Cards	9
Overview-Entering in Data	10
Initialization	11
4. PROGRAM MANUAL	12
Clock and Calender Programming Area	12
Daylight Saving Time Programming Area	13
Public and National Holiday Programming Area	14
Signal Programming Area (Option)	15
Basic Programming Area	16
Work Schedule Programming Area	17
Program Print Out	25
5. USER GUIDE	26
Previous Edition/Current Edition	26
Individual Data Clear	30
Previous Wage/Current Wage	31
Previous Summary Print/Current Summary Print	32
Individual Attendance Report	33
'0' Trick Calculation	34
ZONE Rate Calculation	36
6. BEFORE OPERATION	38
CONNECT THE LITHIUM BATTERY JUMPER	38
7. CONNECTING THE SIGNAL WIRE	39
8. MAINTENANCE	40
Replacing Ribbon Cartridge	40

9. ERROR CODE LIST	41
10. APPENDIX	42
List of Print Symbol Codes	42

GENERAL

SPECIFICATIONS

Power Supply	: AC 100V/115V/120V/240V \pm 10%
Ambient Temperature	: -10°C ~ 45°C
Humidity	: 20% – 90% non-condensing
Power Consumption	: Normal 25 VA, Maximum 75 VA
Dimensions	: 220W \times 145D \times 316H/mm
Weight	: 4 kg
Employee Capacity	: 200 employees
Ribbon	: Two color cartridge
Battery Back Up	: Retains data and advances clock for 3 years
Mounting	: Wall or table mount
Full Power Reserve	: 4 hours or 200 punches
Signals	: (Optional) Rings up to 30 signals

GENERAL

HARDWARE DIAGRAM

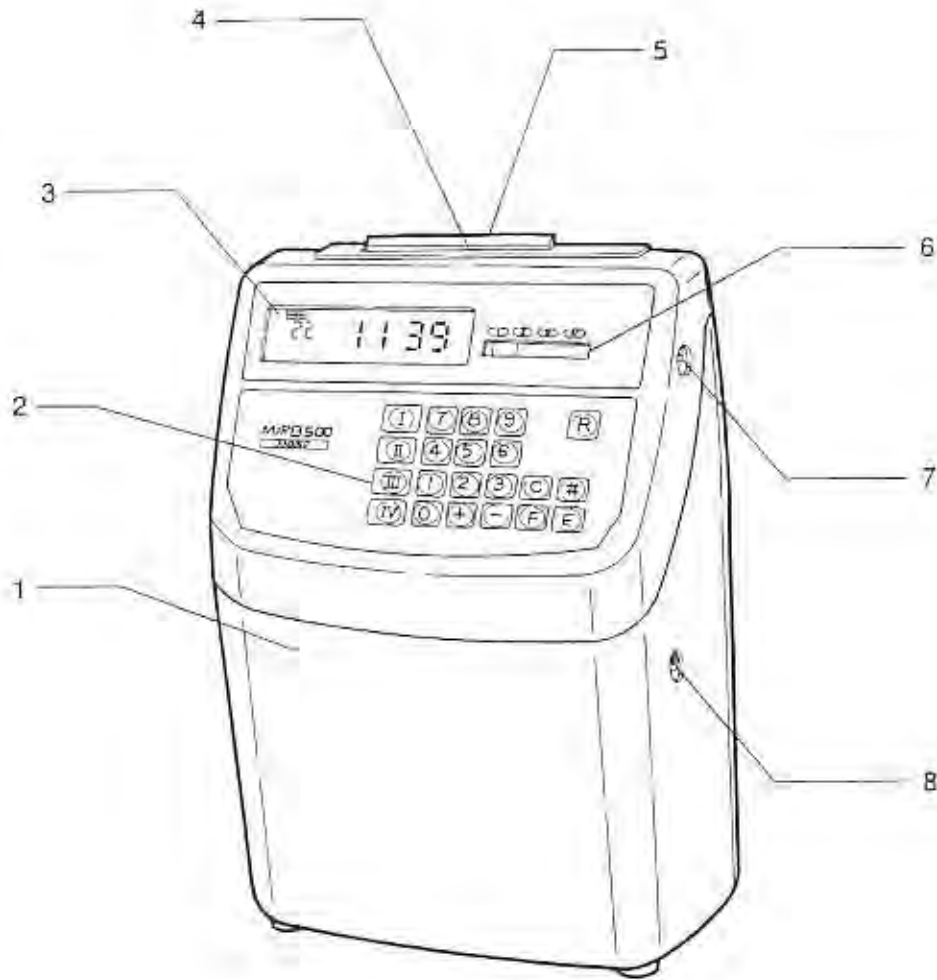

- 1. Case
- 2. Keypad : Numeric membrane keypad.
- 3. Display : Display date, day of week, time, AM/PM, program functions, etc.
- 4. Card Pocket : Card insert.
- 5. Pocket Dust Cover : Close cover in dusty areas when not in use.
- 6. Function Guide : Displays function headings.
- 7. Function Guide Key Switch : Changes function guide headings.
- 8. Cover Panel Key Lock : Unlock/Lock cover lid.

INSTALLATION

WALL MOUNTING

1. Mount by using 4 wood screws. If the wall is made of a soft material use screw anchors or mount the unit on a mounting plate that is securely fastened to the wall.

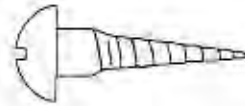

2. Knock out the two mounting holes by pushing a philips screwdriver thru the holes from the inside of the unit.

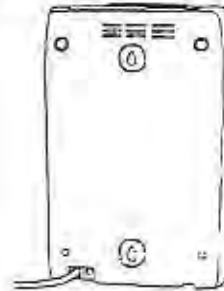

3. Mount one screw 100cm to 130cm from the floor and another 22cm directly below the first. Leave a 0.5mm space between the wall and the screwheads.

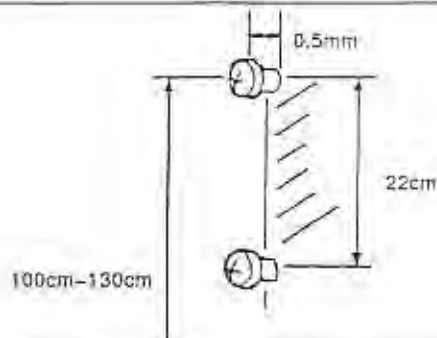

4. Hang the unit on the screws by the slotted holes. Push the unit down so the screws slip into the top part of the holes.

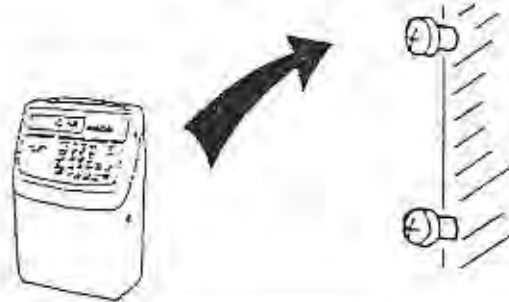

5. Firmly secure the unit with the 2 remaining screws.

NOTE: Avoid mounting the unit in direct sunlight and in damp or dusty areas.

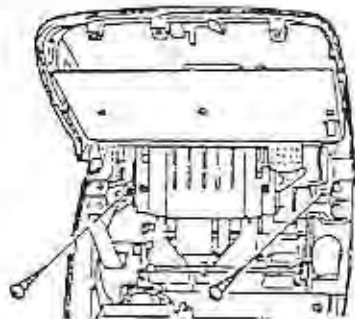

GETTING STARTED

KEYPAD

There are 10 numeric keys and 11 additional keys on the membrane keypad.

I	7	8	9	R	
II	4	5	6		
III	1	2	3	F	C
IV	0	+	-	*	E

0 - **9** = Numeric keys - Used to input data.

R = Reset key - Used to reset display after an error code.

C = Clear key - Clears data incorrectly entered from keypad.

***** = Asterisk key - Used to register set points.

+, **-** = Plus, Minus Keys - Used for adding or subtracting hours when making data corrections.

F = Find key - Locate a specific address number by pressing "F", entering in the address number, followed by "E".

E = Enter key - Saves program data and employee data.

I, **II**, **III**, **IV** = Roman Numeral keys - Used to select program areas.

GETTING STARTED

FUNCTION GUIDE

The MJR-8500 features a function guide for easy access to clock function and programming modes. The function guide has 8 rows, 1 for normal operation and 7 for management functions and programming.

MODE	I	II	III	IV	EXPLANATION
P-0					NORMAL OPERATION
P-1	CLOCK	D.L.S.	HOLIDAY	SIGNAL	SETTING THE CLOCK, DAYLIGHT SAVING TIME, HOLIDAY, TIME SIGNAL (PAGE 12-)
P-2	P.EDIT	C.EDIT		I.CLEAR	MAKING CORRECTIONS ON INDIVIDUAL EMPLOYEES TIME CARDS → PREVIOUS EDITION/CURRENT EDITION (PAGE 26) INDIVIDUAL DATA CLEAR (PAGE 30)
P-3	P.WAGE	C.WAGE	P.PRINT	C.PRINT	SETTING HOURLY WAGE IN REGULAR SHIFT AND PRINTING OUT WAGE DETAILS. → PREVIOUS WAGE/CURRENT WAGE (PAGE 31) SUMMARY PRINT ON TIME CARDS. → PREVIOUS SUMMARY PRINT/CURRENT SUMMARY PRINT (PAGE 32)
P-4					NOT AVAILABLE FOR USE
P-5	P.REPORT	C.REPORT			PRINTING SUMMARY OF WORK TIME ON REPORT CARDS. → PREVIOUS REPORT/CURRENT REPORT (PAGE 33)
P-6	PROG. I	PROG. II		IMPRINT	SETTING OF WORK SCHEDULE, '0' TRICK CALCULATION, ZONE CALCULATION. → PROGRAM I/PROGRAM II (PAGE 17-) PRINTING OUT ALL PROGRAMMED DATA. → IMPRINT (PAGE 26)
P-7	CLEAR			MAINT.	INITIALIZATION (PAGE 11)

TO ACCESS A FUNCTION MODE:

1. Insert the key into the function guide keyhole.
2. Turn the function guide to the row for the mode to be accessed.
3. Press the Roman Numeral key corresponding to the mode to be accessed.

GETTING STARTED

SAMPLE CARDS - EMPLOYEE TIME CARD

Time Card - Records IN/OUT time, accumulated hours, data corrections, and wage calculations.

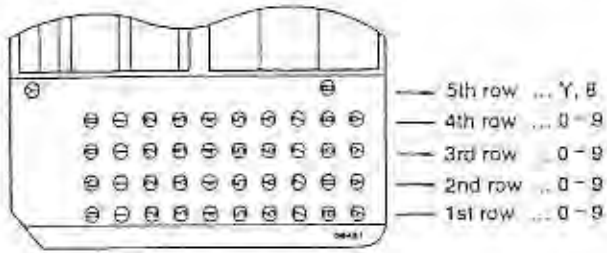

ROW	APPLICATION
1	Machine no. and 1st digit of card no.
2	2nd digit of card no.
3	3rd digit of card no.
4	0 must always be punched.
5	Y & B must always be punched.

The time card has five rows of numbers for perforation on the bottom front side. Cards may be purchased pre-punched or prepared manually with the hand puncher provided. Refer to the above chart for unperforated card preparation.

NO. _____			PAY PERIOD (MONTH)		1
NAME _____					
DATE	IN	OUT	HOURE PUNCE	ACCM. HOURS	OVERTIME
12ND	8:00	12:01	4:00	4:00	
12ND	12:59	18:10	9:00	8:00	1:00
13TH	7:59	12:05	4:00	12:00	
13TH	12:50	17:02	6:00	16:00	
14TH	8:05	12:02	2:50	19:30	
14TH	12:59				
15TH	7:46	RET/REG	24:30	20:30	
		OT-REG	1:00	0:00	0:00
		ZONE-REG	0:00	0:00	0:00
15TH	8:01	12:00	3:30	27:00	
15TH	13:02	17:00	7:00	30:30	
16TH	7:56	12:05	4:00	34:30	
16TH	13:00	22:05	13:30	38:30	0:30
17TH	8:02	12:05	3:30	38:30	1:00
17TH	12:54	17:02	7:30	38:30	1:00
18TH	8:00	12:02	4:00	38:30	1:00
19TH	REG.	8:00	38:30		306.00
	OT-A	1.50	7:00		84.00
	OT-B	2.00	11:00		176.00
	OT-C	2.00	0:00		0.00
	ZONE-A	0.50	0:00		0.00
	ZONE-B	1.00	0:00		0.00
	ZONE-C	1.00	0:00		0.00
	TOTAL				568.00

GETTING STARTED

SAMPLE CARD – AUTHORIZATION CARDS

The Revision/Lock Out Authorization Card is used to override programmed revisions and lock out zones.

The Lock Out Authorization Card is used to override programmed lock out zones only.

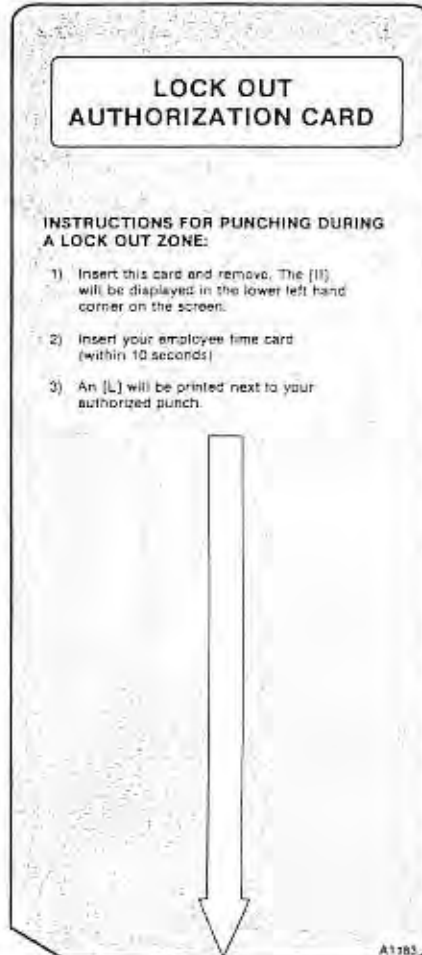
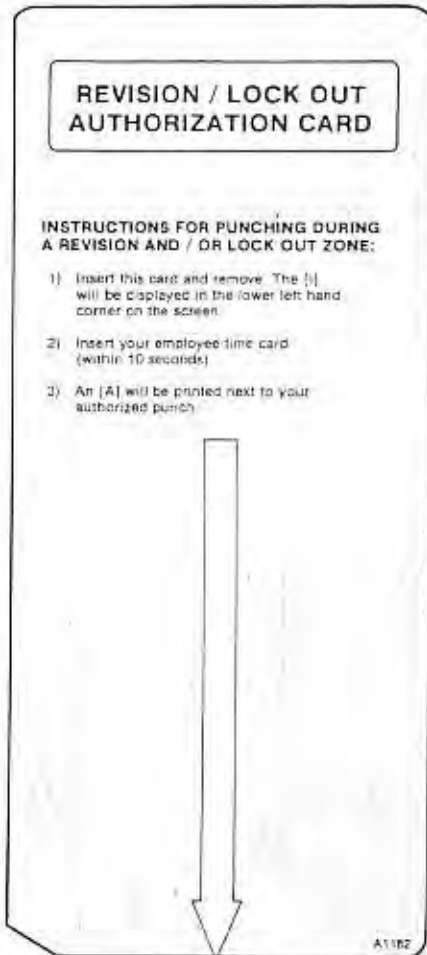

GETTING STARTED

SAMPLE CARDS - REPORT CARD

The report card is used for all reports and lists.

INDIVIDUAL ATTENDANCE REPORT (PREVIOUS)				
1992/10/19 8:30 PAGE- 1				
CARD NO.	R.E.G.	01-A	01-B	01-C
		ZONE-A	ZONE-B	ZONE-C
004	35:30	10:00	21:00	0:00
		0:00	0:00	0:00
005	35:30	10:00	21:00	0:00
		0:00	0:00	0:00
006	35:30	10:00	16:00	0:00
		0:00	0:00	0:00
007	35:30	7:00	2:30	0:00
		0:00	0:00	0:00
008	35:30	10:00	21:00	0:00
		0:00	0:00	0:00
TTL.	177:30	47:00	81:30	0:00
		0:00	0:00	0:00

GETTING STARTED

SAMPLE CARDS – PROGRAM CHECK CARDS

The Program check card is used when performing the program print out.

One copy of the program print out should be kept with the clock and another should be given to the Amano Representative.

LIST P1 1993 5-27 19:44 SUM 3578

P-1-II
1 707 0

P-1-III
1 101 102 103 104
5 105 501 502 503
9 504 505 506 507
13 508 509 510 1224

P-1-IV
0 15
1 2255 6 2300
3 5 2359 4 0
5 2 30 2 140
7 1 257 123 300
9 2256 444 345 555
11 12345 900 67 1200
13 1234567 1500 23456 1730
15 1557 1915

LIST P1 1993 5-27 19:45 SUM 3578

1 3
10 0 0 0

100 0 4 4 897 899
101 3500 4000
102 0 0 0
103 200 300 400
104 25 50 75
105 0
106 6 5 9
107 1 300
108 0 0 0 0 0 0
111 0 0 5 0 0 0
114 0 0 0 0 0 0
117 0 0 0 0 0 0
120 800 1000 1 0 0 0
122 0 0 0 0 0 0

GETTING STARTED

OVERVIEW – ENTERING IN DATA

1. Selections to clock areas are made by using the key to turn the function guide to the desired function row and entering the corresponding Roman numeral for the selected area. Each program area uses address numbers and step numbers. The step number is the area within an address number where specific data is entered to tell the clock how to operate. The address number tells the MJR-8500 where this specific data is to be stored in memory.
2. There are different types of specific data that can be entered in a step number. These types appear in the Program Codes and Descriptions column of each program chart.
 - a) Code Numbers – Enter a code number that corresponds to the given value.
(Example: 0 = Weekly where 0 is the code number which is entered into the step number).
 - b) Dates – Year, month and date is entered into the step number. (Example: 1993 for the year, 1225 for the month and date)
 - c) Hours – All hours must be entered in military hours (0000 – 2359)
 - d) Minutes – All minutes must be entered in regular minutes (00 – 60) regardless of how the clock is set up to display and print the hours.
EXCEPTION: If the clock is set up to print in hundredth hours then you must enter hundredth hours when making data corrections.
3. Programming of day (Monday through Sunday) will be in numeric codes as follows:

1	Monday	6	Saturday
2	Tuesday	7	Sunday
3	Wednesday	8	Monday through Friday
4	Thursday	9	Monday through Sunday
5	Friday		
4. Each program area has an address number that will appear in the upper left corner of the display with the step number directly beneath it.
 - a) Enter the data followed by the 'E' key to advance to the next step or address number.
 - b) To clear data in the display, press the 'C' key before pressing the 'E' key. The data will then return to the original data.
 - c) At the completion of a program area, press the '*' key to save the data into memory. If you forget this step the entered data will be erased automatically and the program area will have to be reprogrammed.

GETTING STARTED

INITIALIZATION

Before you begin using the MJR-8500 you need to clear the memory by initializing the clock.

1. Plug the AC cord into an outlet. The printer will move back and forth and the display will show a time or the error code 8-80.
2. Turn the function guide to row 7 and press the **I** key to access the maintenance area.
3. There are 3 initialization codes available for clearing the memory in the clock. You can clear all of the memory, program data only, employee hours data.
 - a) CLEAR ALL MEMORY: This operation should be performed before you begin using the clock for the first time.
 - Press '32 E 64 E'
 - Turn the function guide back to the normal position.
 - b) CLEAR PROGRAMMED DATA ONLY: This operation will clear all program data.
 - Press '31 E 99 E'
 - Turn the function guide back to the normal position.
 - c) CLEAR EMPLOYEE HOURS DATA ONLY: This operation will clear all employee data files.
 - Press '30 E 88 E'
 - Turn the function guide back to the normal position.

PROGRAM MANUAL

CLOCK AND CALENDAR PROGRAMMING AREA

– TO ENTER PROGRAM AREA – TURN THE FUNCTION GUIDE TO ROW 1 AND PRESS **I**

REFER TO THE "OVERVIEW – ENTERING IN DATA" (Page 10).

PROGRAM ADDRESS NO.	SAMPLE DATA	PROGRAM CODES AND EXAMPLES	PROGRAM DATA
1	1 9 9 3 E	Calendar year (1993)	<input type="text"/> <input type="text"/> <input type="text"/> <input type="text"/> E
2	5 1 8 E	Month day Date (May 18th)	<input type="text"/> <input type="text"/> <input type="text"/> E
3	1 5 2 8 E	Hour and Minute (PM 3:28)	<input type="text"/> <input type="text"/> <input type="text"/> <input type="text"/> E

The display will return to the P – 1 function menu and the data is then automatically saved.

– Turn function guide back to "NORMAL" mode.

PROGRAM MANUAL

DAYLIGHT SAVING TIME PROGRAMMING AREA

- TO ENTER PROGRAM AREA – TURN THE FUNCTION GUIDE TO ROW 1 AND PRESS II
- REFER TO THE “OVERVIEW – ENTERING IN DATA” (Page 10).

PROGRAM ADDRESS NO.	SAMPLE DATA	PROGRAM CODES AND EXAMPLES	PROGRAM DATA
1	3 2 5 E	Month and Date Daylight Saving Time start on. (March 25th)	E
2	9 3 0 E	Month and Date Daylight Saving Time end on. (September 30th)	E

The display will return to the P – 1 function menu and the data is then automatically saved.

- Turn function guide back to “NORMAL” mode.

PROGRAM MANUAL

PUBLIC AND NATIONAL HOLIDAY PROGRAMMING AREA

– TO ENTER PROGRAM AREA – TURN THE FUNCTION GUIDE TO ROW 1 AND PRESS III

IMPORTANT: REMEMBER UPON COMPLETION OF THE PUBLIC AND NATIONAL HOLIDAY PROGRAMMING AREA, BE SURE TO PRESS THE * KEY TO SAVE THE DATA INTO MEMORY.

OTHERWISE THE DATA WILL BE LOST.

– Turn function guide back to "NORMAL" mode

PROGRAM ADDRESS NO.	SAMPLE DATA	PROGRAM CODES AND EXAMPLES	PROGRAM DATA
001 1	1 0 1	Month and Date for public and National holidays (Jan. 1st)	E
002 1			E
003 1			E
004 1			E
005 1			E
006 1			E
007 1			E
008 1			E
009 1			E
010 1			E
011 1			E
012 1			E
013 1			E
014 1			E
015 1			E
016 1			E

PROGRAM MANUAL

SIGNAL PROGRAMMING AREA (OPTION)

– TO ENTER PROGRAM AREA – TURN THE FUNCTION GUIDE TO ROW 1 AND PRESS **IV**

REFER TO THE "OVERVIEW – ENTERING IN DATA" (Page 10).

IMPORTANT: REMEMBER, UPON COMPLETION OF THE SIGNAL PROGRAMMING AREA, BE SURE TO PRESS THE ***** KEY TO SAVE THE DATA INTO MEMORY.

OTHERWISE THE DATE WILL BE LOST.

PROGRAM ADDRESS NO.	SAMPLE DATA	PROGRAM CODES AND EXAMPLES	PROGRAM DATA
00 1	1 0 E	Signal duration-programmable for maximum 15 seconds (Example 10 Sec.). Note: If the signal is not applicable, enter 0 .	E
01 1 2	1 3 5 E 1 0 1 5 E	1st step parameter: to be programmed for applicable days of week in code number.	E E
02 1 2	8 E 1 2 0 0 E	Day code numbers: 1 : Monday 2 : Tuesday 3 : Wednesday 4 : Thursday 5 : Friday 6 : Saturday 7 : Sunday 8 : Monday through Friday 9 : Monday through Sunday	E E
03 1 2			E E
04 1 2		2nd step parameter: to be programmed for signal time in 0 – 23 hours and minutes.	E E
05 1 2		Note: If the signal is applicable for Monday, Wednesday, and Friday, key in as follows: 1 3 5 E , and be sure to check that the display shows the abbreviations of MON, WED, and FRI after pressing the number key.	E E
06 1 2		If the signal is applicable for Monday through Friday, enter just 8 E .	E E
07 1 2			E E
08 1 2			E E
09 1 2		IMPORTANT: Upon completion of Signal programming area, be sure to press * key to enter the data.	E E
10 1 2			E E
11 1 2			E E
12 1 2			E E
13 1 2			E E
14 1 2			E E
15 1 2			E E

PROGRAM MANUAL

BASIC PROGRAMMING AREA

– TO ENTER PROGRAM AREA – TURN THE FUNCTION GUIDE TO ROW 6 AND PRESS **I**

REFER TO THE "OVERVIEW – ENTERING IN DATA" (Page 10).

IMPORTANT: REMEMBER UPON COMPLETION OF THE BASIC PROGRAMMING AREA, BE SURE TO PRESS THE ***** KEY TO SAVE THE DATA INTO MEMORY.

OTHERWISE THE DATA WILL BE LOST.

– Turn function guide back to "NORMAL" mode

PROGRAM ADDRESS NO.	SAMPLE DATA		PROGRAM CODES AND EXAMPLES		PROGRAM DATA					
001 1			0	E	Machine number-programmable for 0 – 9. Single machine use, enter 0. More than one machine, enter the first digit of the timecard number assigned to the machine. Timecard Nos: 000 – 199, enter 0 Timecard Nos: 100 – 299, enter 1 Timecard Nos: 200 – 399, enter 2					E
002 1			1	E	Imprint of hours for IN/OUT time. 0: 0 – 23 Hours (military time) 1: 1 – 12/1 – 12 AM/PM Hours (Underline for PM Hours)					E
002 2			0	E	Imprint of the processed time. 0: Regular minute (00 – 59) 1: 1/100th of hour (00 – 98)					E
002 3			0	E	Imprint of day of the week. 0: English days (MO..... SA, SU) 1: French days (LU SA, DI) 2: German days (MO..... SA, SO) 3: Spanish days (LU SA, DO) 4: Italian days (LU SA, DO) 5: Day numbers (1 6, 7)					E

PROGRAM MANUAL

WORK SCHEDULE PROGRAMMING AREA

- TO ENTER PROGRAM AREA - TURN THE FUNCTION GUIDE TO ROW 6 AND PRESS **II**

REFER TO THE "OVERVIEW - ENTERING IN DATA" (Page 10).

IMPORTANT: REMEMBER UPON COMPLETION OF THE WORK SCHEDULE PROGRAMMING AREA, BE SURE TO PRESS THE ***** KEY TO SAVE THE DATA INTO MEMORY.

OTHERWISE THE DATA WILL BE LOST.

- Turn function guide back to "NORMAL" mode.

PROGRAM ADDRESS NO.	SAMPLE DATA	PROGRAM CODES AND EXAMPLES	PROGRAM DATA																																																																		
100 1		3 E 1st step parameter: Pay period (monthly payroll) 0: weekly 1: bi-weekly 2: semi-monthly 3: monthly	E																																																																		
2		3 1 E 2nd step parameter: Pay ending day or date Weekly/bi-weekly : day No. Semi-monthly : enter 15 or other Monthly : enter 31 or other	E																																																																		
3		7 E 3rd step parameter : Week ending day (sunday) In case of monthly, enter 7. In case of weekly/bi-weekly, don't enter.	E																																																																		
101 1	4 0 0 0	E 1st step parameter: Maximum non-overtime hours per week. Hours exceeding this amount will be stored as overtime category A.	E																																																																		
2	4 8 0 0	E 2nd step parameter: Maximum weekly hours for overtime category A. Hours exceeding this amount will be stored as overtime category B. Example: The hours over 40 hours per week are stored as overtime category A, and over 48 hours as category B. If overtime category B is not required enter 0 in 2nd step parameter. If no overtime classification is required, enter 0 is both 1st and 2nd step parameters.	E																																																																		
102 1		1 5 E 1st step parameter: Time rounding: rounding unit for both IN/OUT time.	E																																																																		
2		6 E 2nd step parameter: In-time rounding point.	E																																																																		
3		1 0 E 3rd step parameter: Out-time rounding point.	E																																																																		
<p>Example: refer to below</p> <table style="margin: auto; border-collapse: collapse;"> <tr> <td style="text-align: left;">IN</td> <td style="text-align: center;">←</td> <td style="text-align: center;">.....</td> <td style="text-align: center;"> </td> <td style="text-align: center;">.....</td> <td style="text-align: center;">→</td> </tr> <tr> <td>00</td> <td></td> <td>5</td> <td>8</td> <td></td> <td>15</td> </tr> <tr> <td>15</td> <td></td> <td>20</td> <td>21</td> <td></td> <td>30</td> </tr> <tr> <td>30</td> <td></td> <td>35</td> <td>36</td> <td></td> <td>45</td> </tr> <tr> <td>45</td> <td></td> <td>50</td> <td>51</td> <td></td> <td>00</td> </tr> <tr> <td colspan="6"> </td> </tr> <tr> <td style="text-align: left;">OUT</td> <td style="text-align: center;">←</td> <td style="text-align: center;">.....</td> <td style="text-align: center;"> </td> <td style="text-align: center;">.....</td> <td style="text-align: center;">→</td> </tr> <tr> <td>00</td> <td></td> <td>9</td> <td>10</td> <td></td> <td>15</td> </tr> <tr> <td>15</td> <td></td> <td>24</td> <td>25</td> <td></td> <td>30</td> </tr> <tr> <td>30</td> <td></td> <td>39</td> <td>40</td> <td></td> <td>45</td> </tr> <tr> <td>40</td> <td></td> <td>54</td> <td>55</td> <td></td> <td>00</td> </tr> </table>				IN	←	→	00		5	8		15	15		20	21		30	30		35	36		45	45		50	51		00							OUT	←	→	00		9	10		15	15		24	25		30	30		39	40		45	40		54	55		00
IN	←	→																																																																
00		5	8		15																																																																
15		20	21		30																																																																
30		35	36		45																																																																
45		50	51		00																																																																
OUT	←	→																																																																
00		9	10		15																																																																
15		24	25		30																																																																
30		39	40		45																																																																
40		54	55		00																																																																

PROGRAM MANUAL

PROGRAM ADDRESS NO.	SAMPLE DATA	PROGRAM CODES AND EXAMPLES	PROGRAM DATA																																												
103 1	1 5 0 E	1st step parameter: Pay rate multiplier for overtime category - A	E																																												
2	2 0 0 E	2nd step parameter: Pay rate multiplier for overtime category - B	E																																												
3	3 0 0 E	3rd step parameter: Pay rate multiplier for overtime category - C	E																																												
104 1	0 2 5 E	1st step parameter: Pay rate multiplier for time zone - A	E																																												
2	0 5 0 E	2nd step parameter: Pay rate multiplier for time zone - B	E																																												
3	0 7 5 E	3rd step parameter: Pay rate multiplier for time zone - C	E																																												
105 1	1 E	1st step parameter: Decimal point 0: Without Decimal point, 1: With Decimal point	E																																												
106 1	6 E	1st step parameter: Weekly 1st non-working day (1-7)	E																																												
2	7 E	2nd step parameter: Weekly 2nd non-working day (1-7)	E																																												
3	0 E	3rd step parameter: Pay rate schedule (0-9)	E																																												
<table border="1" style="width: 100%; border-collapse: collapse;"> <thead> <tr> <th style="width: 5%;">Code No.</th> <th style="width: 20%;">1st Weekly non-working day</th> <th style="width: 20%;">2nd Weekly non-working day</th> <th style="width: 35%;">Public and National Holiday</th> </tr> </thead> <tbody> <tr><td>0</td><td>OT - A</td><td>OT - B</td><td>OT - C</td></tr> <tr><td>1</td><td>OT - A</td><td>OT - A</td><td>OT - A</td></tr> <tr><td>2</td><td>OT - A</td><td>OT - B</td><td>OT - B</td></tr> <tr><td>3</td><td>OT - A</td><td>OT - B</td><td>OT - A</td></tr> <tr><td>4</td><td>OT - A</td><td>OT - C</td><td>OT - C</td></tr> <tr><td>5</td><td>OT - B</td><td>OT - B</td><td>OT - B</td></tr> <tr><td>6</td><td>OT - B</td><td>OT - B</td><td>OT - C</td></tr> <tr><td>7</td><td>REG</td><td>OT - A</td><td>OT - A</td></tr> <tr><td>8</td><td>REG</td><td>OT - A</td><td>OT - B</td></tr> <tr><td>9</td><td>REG</td><td>OT - B</td><td>OT - C</td></tr> </tbody> </table>				Code No.	1st Weekly non-working day	2nd Weekly non-working day	Public and National Holiday	0	OT - A	OT - B	OT - C	1	OT - A	OT - A	OT - A	2	OT - A	OT - B	OT - B	3	OT - A	OT - B	OT - A	4	OT - A	OT - C	OT - C	5	OT - B	OT - B	OT - B	6	OT - B	OT - B	OT - C	7	REG	OT - A	OT - A	8	REG	OT - A	OT - B	9	REG	OT - B	OT - C
Code No.	1st Weekly non-working day	2nd Weekly non-working day	Public and National Holiday																																												
0	OT - A	OT - B	OT - C																																												
1	OT - A	OT - A	OT - A																																												
2	OT - A	OT - B	OT - B																																												
3	OT - A	OT - B	OT - A																																												
4	OT - A	OT - C	OT - C																																												
5	OT - B	OT - B	OT - B																																												
6	OT - B	OT - B	OT - C																																												
7	REG	OT - A	OT - A																																												
8	REG	OT - A	OT - B																																												
9	REG	OT - B	OT - C																																												
107 1	0 E	1st step parameter: Day change time (see note A, page 17) 0: Open mode: day change time auto-matically 13 hours after last IN-punching, or at actual day-change-time (parameter 2). 1: Fixed mode: accumulation ends at actual day-change-time.	E																																												
2	1 0 0 E	2nd step parameter: Actual day change time.	E																																												
108 1	3 0 0 E	Automatic break time deduction after net worked hours for <u>SHIFT 1</u>	E																																												
2	3 0 E	Example: If net worked hours exceed 3:00 hours, 30 minutes are automatically deducted as a break.	E																																												
109 1	5 0 0 E	Example: If total worked hours on one day are more than 6:30, a total of 1:30 will be deducted.	E																																												
2	1 0 0 E		E																																												
110 1	9 0 0 E	If input data is greater than or equal to 60, data will be converted to hours and minutes.	E																																												
2	4 5 E	Example: "90 min." → 1:30	E																																												

PROGRAM MANUAL

PROGRAM ADDRESS NO.	SAMPLE DATA	PROGRAM CODES AND EXAMPLES	PROGRAM DATA	
111 1		Automatic break time deduction after net worked hours for <u>SHIFT II</u> .	E	
2			E	
112 1			E	
2			E	
113 1			E	
2			E	
114 1		Automatic break time deduction after net worked hours for <u>SHIFT III</u> .	E	
2			E	
115 1			E	
2			E	
116 1			E	
2			E	
117 1		Automatic break time deduction after net worked hours for <u>SHIFT IV</u> .	E	
2			E	
118 1			E	
2			E	
119 1			E	
2			E	
120 1	8 0 0	1st step parameter: Maximum non-overtime hours per day. Hours exceeding this amount will be stored as overtime category A. For <u>SHIFT I</u> .	E	
2	1 0 0 0		2nd step parameter: Maximum hours for overtime category A. Hours exceeding this amount will be stored as overtime category B. For <u>SHIFT I</u> .	E
3	0		3rd step parameter: "0" Trick mode 0: No "0" Trick, 1: "0" Trick.	E
121 1		Same as 120, for <u>SHIFT II</u> .	E	
2			E	
3			E	

PROGRAM MANUAL

PROGRAM ADDRESS NO.	SAMPLE DATA	PROGRAM CODES AND EXAMPLES	PROGRAM DATA
122 1		Same as 120, for <u>SHIFT III</u> .	E
2	E		
3	E		
123 1		Same as 120, for <u>SHIFT IV</u> .	E
2	E		
3	E		
130 1		Work schedule definition for <u>SHIFT I</u> . When programming the addresses 130 – 137 refer to the explanation of codes below.	E
2	X X X X		E
3	Y Y Y Y		E
131 1		1st step parameter: Code numbers (A) 0: Not applicable 1: First in-punch revision time zone 2: Out-punch revision time zone 3: In-punch revision time zone 4: First in-punch lock out time zone 5: Out-punch lock out time zone 6: In-punch lock out time zone 7: Fixed break time zone (unpaid)	E
2			E
3			E
132 1		8: Time Zone – A 9: Time Zone – B 10: Time Zone – C	E
2			E
3			E
133 1		2nd step parameter Zone starting time (XXXX)	E
2			E
3			E
134 1		3rd step parameter Zone ending time (YYYY)	E
2			E
3			E
135 1			E
2			E
3			E

PROGRAM MANUAL

PROGRAM ADDRESS NO.	SAMPLE DATA				PROGRAM CODES AND EXAMPLES	PROGRAM DATA
136 1					E	E
2					E	E
3					E	E
137 1					E	E
2					E	E
3					E	E
140 1				A	E	E
2	X	X	X	X	E	E
3	Y	Y	Y	Y	E	E
141 1					E	E
2					E	E
3					E	E
142 1					E	E
2					E	E
3					E	E
143 1					E	E
2					E	E
3					E	E
144 1					E	E
2					E	E
3					E	E
145 1					E	E
2					E	E
3					E	E

Work schedule definition for **SHIFT II** :
When programming the addresses 140 – 147 refer to the explanation of codes below.

- 1st step parameter:
Code numbers (A)
0: Not applicable
1: First in-punch revision time zone
2: Out-punch revision time zone
3: In-punch revision time zone
4: First in-punch lock out time zone
5: Out-punch lock out time zone
6: In-punch lock out time zone
7: Fixed break time zone (unpaid)
8: Time Zone – A
9: Time Zone – B
10: Time Zone – C

2nd step parameter
Zone starting time (XXXX)

3rd step parameter
Zone ending time (YYYY)

PROGRAM MANUAL

PROGRAM ADDRESS NO.	SAMPLE DATA				PROGRAM CODES AND EXAMPLES	PROGRAM DATA
146 1					E	E
2					E	E
3					E	E
147 1					E	E
2					E	E
3					E	E
150 1				A	E	E
2	X	X	X	X	E	E
3	Y	Y	Y	Y	E	E
151 1					E	E
2					E	E
3					E	E
152 1					E	E
2					E	E
3					E	E
153 1					E	E
2					E	E
3					E	E
154 1					E	E
2					E	E
3					E	E
155 1					E	E
2					E	E
3					E	E

Work schedule definition for SHIFT III.
When programming the addresses 150 – 157 refer to the explanation of codes below.

1st step parameter:

Code numbers (A)

0: Not applicable

1: First in-punch revision time zone

2: Out-punch revision time zone

3: In-punch revision time zone

4: First in-punch lock out time zone

5: Out-punch lock out time zone

6: In-punch lock out time zone

7: Fixed break time zone (unpaid)

8: Time Zone – A

9: Time Zone – B

10: Time Zone – C

2nd step parameter

Zone starting time (XXXX)

3rd step parameter

Zone ending time (YYYY)

PROGRAM MANUAL

PROGRAM ADDRESS NO.	SAMPLE DATA				PROGRAM CODES AND EXAMPLES	PROGRAM DATA
156 1					E	
2					E	
3					E	
157 1					E	
2					E	
3					E	
160 1				A	E	Work schedule definition for <u>SHIFT IV</u> . When programming the addresses 160 – 167 refer to the explanation of codes below.
2	X	X	X	X	E	
3	Y	Y	Y	Y	E	1st step parameter: Code numbers (A) 0: Not applicable
161 1					E	1: First in-punch revision time zone
2					E	2: Out-punch revision time zone
3					E	3: In-punch revision time zone
162 1					E	4: First in-punch lock out time zone
2					E	5: Out-punch lock out time zone
3					E	6: In-punch lock out time zone
163 1					E	7: Fixed break time zone (unpaid)
2					E	8: Time Zone – A
3					E	9: Time Zone – B
164 1					E	10: Time Zone – C
2					E	2nd step parameter: Zone starting time (XXXX)
3					E	
165 1					E	3rd step parameter: Zone ending time (YYYY)
2					E	
3					E	
166 1					E	
2					E	
3					E	
167 1					E	
2					E	
3					E	

PROGRAM MANUAL

PROGRAM ADDRESS NO.	SAMPLE DATA					PROGRAM CODES AND EXAMPLES	PROGRAM DATA				
166 1					E						E
2					E						E
3					E						E
167 1					E						E
2					E						E
3					E						E
170 1	1	2	3	4	E	Applicable days for <u>SHIFT I</u> . (Example: Monday through Thursday)					E
171 1					E	Applicable days for <u>SHIFT II</u> .					E
172 1					E	Applicable days for <u>SHIFT III</u> .					E
173 1					E	Applicable days for <u>SHIFT IV</u> . 1: Monday 2: Tuesday 3: Wednesday 4: Thursday 5: Friday 6: Saturday 7: Sunday 8: Monday - Friday 9: Monday - Sunday					E

PROGRAM MANUAL

PROGRAM PRINT OUT

- To Print Out All Programmed Data

1. Turn function guide to row "6".
2. Press **TV** **E** key to access program printing.
3. Insert program check card, when the first page (0) is finished printing the card will automatically be ejected, remove the card and the display will show (1). Reinsert the card on the back side to print the next page. Continue inserting cards until the last page (2) is printed. Press the "E" key to skip pages.

PAGE	PROGRAM
0	DAYLIGHT SAVING TIME PROGRAMMING AREA PUBLIC AND NATIONAL HOLIDAY PROGRAMMING AREA SIGNAL PROGRAMMING AREA (OPTION)
1	BASIC PROGRAMMING AREA WORK SCHEDULE PROGRAMMING AREA (100 - 123)
2	WORK SCHEDULE PROGRAMMING AREA (130 - 173)

4. Turn function guide back to "NORMAL" position.

USER GUIDE

PREVIOUS EDITION/CURRENT EDITION

– TO MAKE CORRECTIONS ON INDIVIDUAL EMPLOYEE'S TIME CARDS

The following codes will allow you to correct accumulated hours on an employee's time card for the current pay period. All corrections will be printed in red. If the clock is set up to calculate in regular minutes then the correction data should be entered in regular minutes (:00 – :59). If the clock is set up to calculate in hundredths then the correction data should be entered in hundredths of an hour (.00 – .98).

1. Turn the function guide to row 2 and press I or II key.

Previous Edition – I

Current Edition – II

2. Insert the time card to be corrected.
3. Remove the card from pocket.
4. Press the "E" key until the desired code number for the category of time to be corrected is displayed.

USER GUIDE

THERE ARE 7 HOUR CATEGORIES FOR CORRECTION (P.EDIT)

THERE ARE 9 HOUR CATEGORIES FOR CORRECTION (C.EDIT)

(The category number will appear as the small number on the left side of the display and the amount of time in that category will also be displayed.)

P.EDIT

CODE No.	CATEGORY
1.	Regular Hours
2.	Overtime – A Hours
3.	Overtime – B Hours
4.	Overtime – C Hours
5.	Time Zone – A Hours
6.	Time Zone – B Hours
7.	Time Zone – C Hours

C.EDIT

CODE No.	CATEGORY
1.	Daily Net Hours
2.	Weekly Net Hours
3.	Regular Hours
4.	Overtime – A Hours
5.	Overtime – B Hours
6.	Overtime – C Hours
7.	Time Zone – A Hours
8.	Time Zone – B Hours
9.	Time Zone – C Hours

(See next page for detailed description)

5. Type in the number of hours and minutes for the correction.
6. Press "+" to add or "-" to subtract.
7. Press "E" to store and advance to next category.
8. When finished making corrections, insert the card to have the corrections printed on. The corrected data will be printed in red.
9. Insert the next card to be corrected or turn the function guide back to the "normal" position.

Note: Maximum enterable data is 249:59.

For over 500 hours of calculation results, maximum enterable data is 500:00.

When correcting daily net hours for current edition, automatic break time deduction is not effected.

Make correction of daily net hours after the final printing of the day.

USER GUIDE

INDIVIDUAL DATA CORRECTION

CATEGORY DESCRIPTIONS

1. **DAILY NET HOURS** – To adjust hours for the current day.
** Hours entered here will automatically be stored into regular and overtime categories based on the daily overtime rules and added to the weekly net hours category.

2. **WEEKLY NET HOURS** – To adjust hours for the current week.
** Hours entered here will automatically go into the regular and overtime categories based on the weekly overtime rules.

For Bi-weekly, semi-monthly and monthly pay periods, the sorting of the corrected hours will be based on the hours calculated during the last week of the pay period.

3. **REGULAR HOURS** – To adjust hours in the accumulated regular hours category ONLY.
** Hours entered here will be added directly to the REGULAR hours category. No other categories will be effected.

4. **OVERTIME A HOURS** – To adjust hours in the accumulated overtime A hours category only.
** Hours entered here will be added directly to the OVERTIME A category. No other categories will be effected.

5. **OVERTIME B HOURS** – To adjust hours in the accumulated overtime B hours category only.
** Hours entered here will be added directly to the OVERTIME B category. No other categories will be effected.

6. **OVERTIME C HOURS** – To adjust hours in the accumulated overtime C hours category only.
* Hours entered here will be added directly to the OVERTIME A category. No other categories will be effected.

7. **TIME ZONE A HOURS** – To adjust hours in the accumulated time zone A hours category only.
* Hours entered here will be added directly to the TIME ZONE A HOURS category. No other categories will be effected.

8. **TIME ZONE B HOURS** – To adjust hours in the accumulated time zone B hours category only.
* Hours entered here will be added directly to the TIME ZONE B HOURS category. No other categories will be effected.

USER GUIDE

9. **TIME ZONE C HOURS** – To adjust hours in the accumulated time zone C hours category only;
- * Hours entered here will be added directly to the TIME ZONE C HOURS category. No other categories will be effected.

USER GUIDE

INDIVIDUAL DATA CLEAR

– TO CLEAR ALL DATA FOR AN INDIVIDUAL EMPLOYEE

1. Turn the function guide to row 2.
2. Press **[IV]** key.
3. Insert employee time card to be cleared. Card number appears on LCD.
4. Press **[E]** key. Machine beeps, clears memory for that employee and automatically ejects time card.
5. Remove card from pocket.
6. Insert any other cards to be cleared or turn function guide back to "normal" position.

USER GUIDE

PREVIOUS WAGE/CURRENT WAGE

Setting hourly wage in regular shift, and printing out wage details.

FOR THE PREVIOUS WAGE

1. Turn the function guide to row 3.
2. Press **I** key.
3. Set hourly wage by key or unit wage card.
4. Insert the time card.

FOR THE CURRENT WAGE

1. Turn the function guide to row 3.
2. Press **II** key.
3. Set hourly wage by key or unit wage card.
4. Insert the time card.

USER GUIDE

PREVIOUS SUMMARY PRINT/CURRENT SUMMARY PRINT

– TO PRINT SUMMARY ON INDIVIDUAL TIME CARD

FOR THE PREVIOUS PAY PERIOD

1. Turn the function guide to row 3.
2. Press **III** key.
3. Insert the employee time card from the previous pay period to have hours calculated
Remove when finished printing.
4. Turn function guide back to the "normal" position.

FOR THE CURRENT PAY PERIOD

1. Turn the function guide to row 3.
2. Press **IV** key.
3. Insert the employee time card from the current pay period to have hours calculated
Remove when finished printing.
4. Turn function guide back to the "normal" position.

USER GUIDE

INDIVIDUAL ATTENDANCE REPORT

– TO PRINT SUMMARIES OF ALL EMPLOYEE'S HOURS ON A REPORT CARD

FOR THE PREVIOUS PAY PERIOD

1. Turn the function guide to row 5.
2. Press **I** key.
3. Insert a report card. Remove when finished printing.
4. Turn function guide back to the "normal" position.

FOR THE CURRENT PAY PERIOD

1. Turn the function guide to row 5.
2. Press **II** key.
3. Insert a report card. Remove when finished printing.
4. Turn function guide back to the "normal" position.

USER GUIDE

'0' TRICK CALCULATION

Setting '0' trick calculation is different pay rates from ordinary shifts. By setting '1' in 0 trick mode, MJR-8500 calculates only OT - A, OT - B, but doesn't calculate REG hours.

Turn the function guide to row 6 and press key. (program address No. 120)

<Not setting '0' trick calculation>

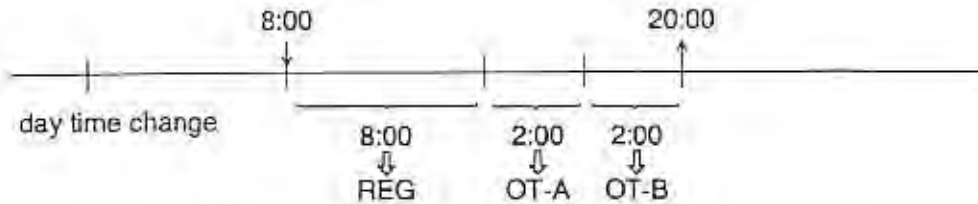

To set the above:

set '8:00' in 1st step parameter

set '10:00' in 2nd step parameter

set '0' in 3rd step parameter

<'0' trick calculation - 1>

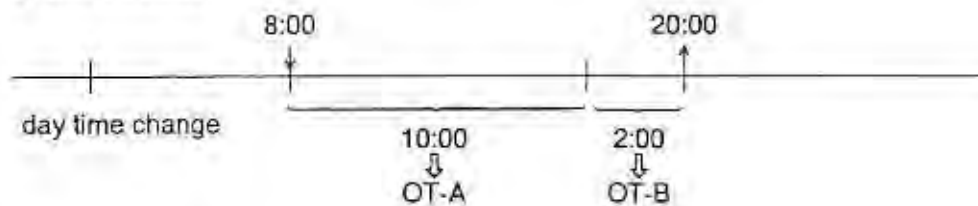

To set the above:

set '0:01' in 1st step parameter

set '10:00' in 2nd step parameter

set '1' in 3rd step parameter

USER GUIDE

<'0' trick calculation - 2>

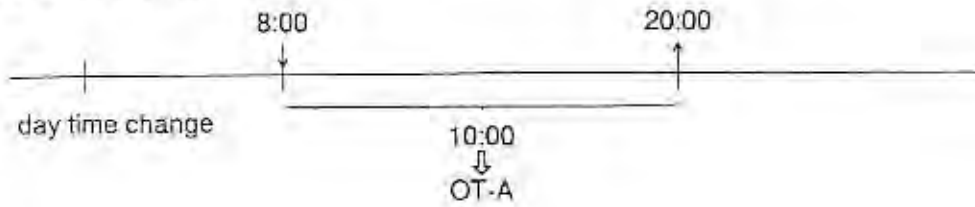

To set the above:

set '0:01' in 1st step parameter

set '0:00' in 2nd step parameter

set '1' in 3rd step parameter

<'0' trick calculation - 3>

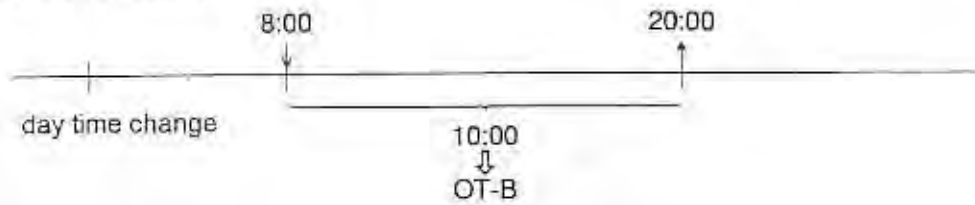

To set the above:

set '0:00' in 1st step parameter

set '0:01' in 2nd step parameter

set '1' 3rd step parameter

USER GUIDE

ZONE RATE CALCULATION

MJR-8500 can calculate 3 kinds of time periods in addition to overtime calculation.

Turn the function guide to row 6 and press II key. (program address No. 130)

※ When setting of zones overlaps, the order of priority is ① zone - C, ② zone - B, ③ zone - A.

<EXAMPLE 1>

over 8 hours ... OT-A

ZONE - A 5:00 ~ 15:00

ZONE - B 15:00 ~ 22:00

ZONE - C 22:00 ~ 0:00 0:00 ~ 5:00

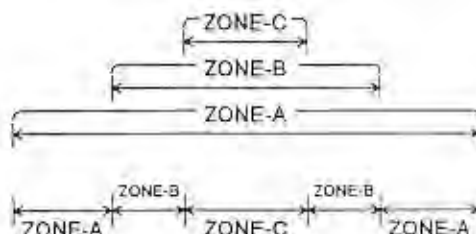

NOTE: It is impossible to set over the programmed day change time.

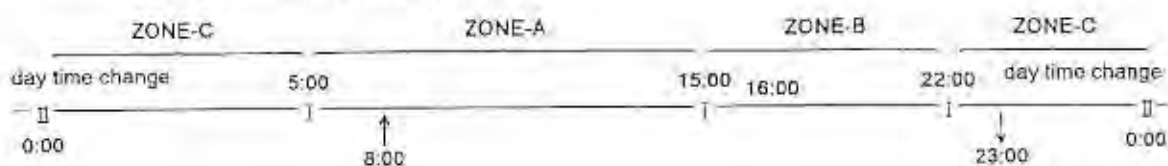

To set the above:

PROGRAM ADDRESS NO.	SAMPLE DATA	PROGRAM CODES AND EXAMPLES	PROGRAM DATA
130 1	A E	Work schedule definition for SHIFT 1. When programming the addresses 130 - 137 refer to the explanation of codes below.	8 E
2	X X X X E		5 0 0 E
3	Y Y Y Y E	1st step parameter: Code numbers (A)	1 5 0 0 E
131 1	E	0: Not applicable	9 E
2	E	1: First in-punch revision time zone	1 5 0 0 E
3	E	2: Out-punch revision time zone	2 2 0 0 E
132 1	E	3: In-punch revision time zone	1 0 E
2	E	4: First in-punch lock out time zone	2 2 0 0 E
3	E	5: Out-punch lock out time zone	0 0 0 E
133 1	E	6: In-punch lock out time zone	1 0 E
2	E	7: Fixed break time zone (unpaid)	0 0 0 E
3	E	8: Time Zone - A	5 0 0 E
		9: Time Zone - B	
		10: Time Zone - C	
		2nd step parameter Zone starting time (XXXX)	
		3rd step parameter Zone ending time (YYYY)	

USER GUIDE

<EXAMPLE 2>

over 8 hours ... OT-A over 10 hours ... OT-B
 ZONE - A 5:00 - 10:00
 ZONE - B Not set
 ZONE - C 22:00 - 0:00 0:00 - 5:00

NOTE: It is impossible to set over the programmed day time change.

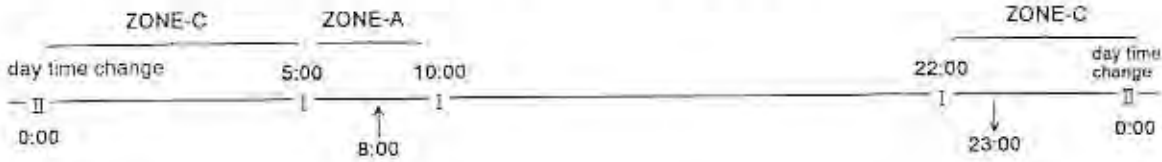

To set the above:

PROGRAM ADDRESS NO.	SAMPLE DATA	PROGRAM CODES AND EXAMPLES	PROGRAM DATA
130 1	A E	Work schedule definition for SHIFT 1 . When programming the addresses 130 - 137 refer to the explanation of codes below.	8 E
2	X X X X E		5 0 0 E
3	Y Y Y Y E	1st step parameter: Code numbers (A) 0: Not applicable	1 0 0 0 E
131 1	E	1: First in-punch revision time zone	1 9 E
2	E	2: Out-punch revision time zone	2 2 0 0 E
3	E	3: In-punch revision time zone	0 0 0 E
132 1	E	4: First in-punch lock out time zone	0 0 0 E
2	E	5: Out-punch lock out time zone	1 0 E
3	E	6: In-punch lock out time zone	0 0 0 E
133 1	E	7: Fixed break time zone (unpaid)	5 0 0 E
2	E	8: Time Zone - A	
3	E	9: Time Zone - B	
134 1	E	10: Time Zone - C	
2	E	2nd step parameter Zone starting time (XXXX)	
3	E	3rd step parameter Zone ending time (YYYY)	
135 1	E		
2	E		
3	E		

BEFORE OPERATION

CONNECT THE LITHIUM BATTERY JUMPER

1. Connect the lithium battery jumper.

The MJR-8500 is shipped with the battery disconnected. To connect the battery, open the keypad cover. On the left side of the EPROM socket, next to the battery, is a jumper socket with a red cover. The red cover must be shorted on the center and right pins.

fig.1

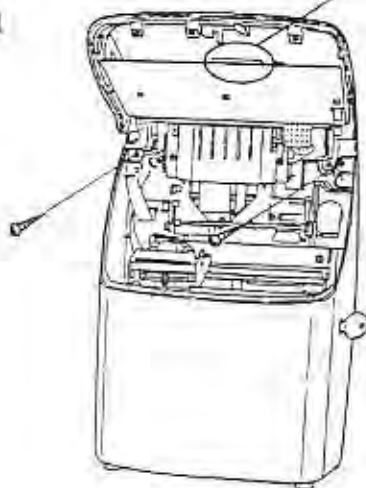

fig.2

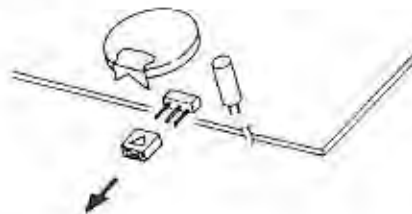

fig.3



2. Initialize the entire memory.

To ensure that no erroneous data exists in the recorder's memory, clear all memory by setting the menu function guide switch

to row 7 and pressing

IV

Then, press '32#64#'.

CONNECTING THE SIGNAL WIRE

1. Remove the cover.

Open the panel cover and remove the 2 screws.

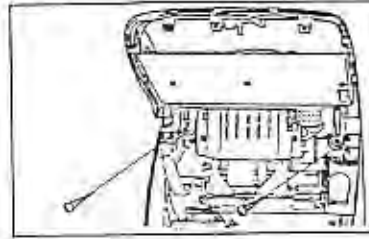

2. Connecting the signal wire.

Punch out perforated hole provided for the signal wire and connect the signal wire to the orange terminal block on the signal kit.

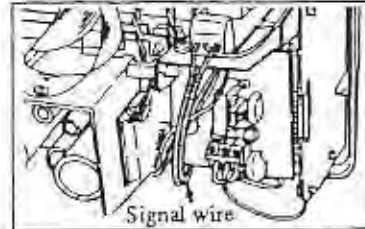

3. Securing the signal wire.

Make sure that the signal wire is secured with the wire tie.

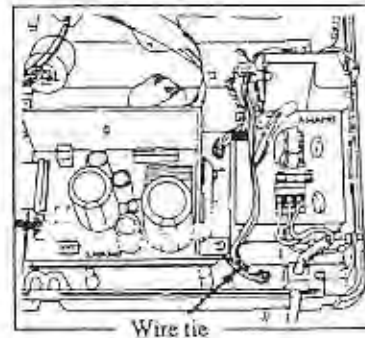

4. Securing the cover with 2 screws.

■ Wiring example

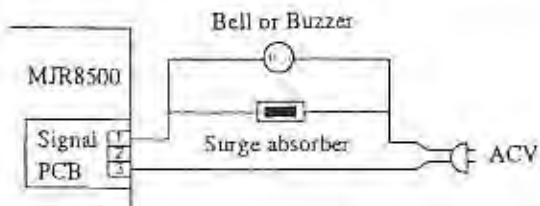

Install the noise filtering capacitor to the signal unit.

• Surge absorber
e.g.) parts No. :ESA100010

MAINTENANCE

REPLACING RIBBON CARTRIDGE

When the printing on the time card becomes too light and difficult to read replace the ribbon cartridge. Use Aramo replacement ribbon number CE-315251.

1. Open the top cover.



2. To remove the ribbon, pull the ribbon holder towards you, so the ribbon pops up. Lift the ribbon to remove it.

RIBBON



3. Place the new cartridge so that the ribbon slips between the ribbon guide and the dot printer head.



4. Turn the knob clockwise to tighten up the ribbon. Close the cover case.

RIBBON GUIDE

DOT PRINTER

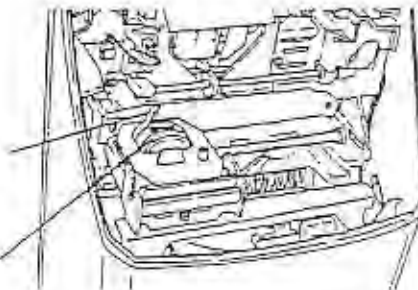

ERROR CODE LIST

ERROR CODE	REASON	SOLUTION
0 - 01 SOFT ERR	Inserted time card facing the wrong way.	Re-insert time card facing the correct way.
0 - 08 SOFT ERR	Inserted wrong card while correcting card data.	Insert correct time card.
0 - 12 SOFT ERR	Inserted time card during lock out period.	Override lock out with lock out release card.
1 - 20 SOFT ERR	Incorrect Machine No. on time card or in programmed data.	Check programmed data in the function guide P-6 II , address 001 and time card number.
1 - 22 SOFT ERR	Inserted incorrectly coded (perforated) time card.	Use properly coded time card.
1 - 30 SOFT ERR	Improper time card. (Too Short)	Reissue proper size, properly coded time card.
1 - 31 SOFT ERR	Improper time card. (Too Long)	Reissue proper size, properly coded time card.
8 - 80 SOFT ERR	Incorrect data programmed.	Clear or reprogram applicable program area.
8 - 85 SOFT ERR	Individual data file reading error.	Clear individual card data for that card.
8 - 88 SOFT ERR	CPU (memory) defect.	Press "C" key to clear.
9 - 50 SOFT ERR	Inserted time card for printing earlier than previously printed time.	Make sure the clock is set to the current date and time.
9 - 60 SOFT ERR	Temporary defect of software caused by noise or surge from outside power source.	Resets automatically in 3 seconds after error display.
9 - 61 HARD ERR	Temporary defect of CPU caused by noise or surge from outside power source.	Reset automatically in 3 seconds after error display.
9 - 70 HARD ERR	Problem with hardware such as printer, sensor, motor, etc.	Clear entry by C key and clean sensors.
9 - 90 HARD ERR	Card reading failure.	Press CL key and call service.
9 - 91 HARD ERR	Card sensor level defect.	Press CL key and call service.

APPENDIX

LIST OF PRINT SYMBOL CODES

CODE	DESCRIPTION
N	PUBLIC/NATIONAL HOLIDAY
H	WEEKLY NON-WORKING DAY
L	REVISION AND LOCK OUT AUTHORIZATION
◆	LOCK OUT AUTHORIZATION
→	CORRECTION, SUMMARY